

LEVIOR s.r.o.
Tovačovská 3488/28, 750 02 PŘEROV
Tel.: 00420 - 581 - 746256-58
Fax: 00420 - 581 - 746255
LEVIOR@LEVIOR.CZ
www.levior.cz

CONCRETE MIXER 162L

Model: CM180L



INSTRUCTIONS FOR INSTALLATION AND OPERATION

Thorough familiarity with this manual and following the instructions contained in this manual concerning operation and maintenance, extend the period of use of the mixer, and will result in customer satisfaction with its use.



EC Declaration of Conformity

according to the Machinery Directive 2006/42/EC

For the following equipment :

Product : Drum Mixers

Type Designation/Trademark : CM180L

Serial Number :

Manufactures Name :Yangzhou Ailida Electromechanical Manufacturing CO.,LTD

Manufactures Address :WeigaoRoad, Gaoyou Town Industrial Park 225600 Gaoyou City,
Jiangsu Province PEOPLE'S REPUBLIC OF CHINA

The manufacturer hereby certifies on his sole responsibility that the product is in compliance with the following regulations:

2000/14/ES

2006/42/EC

2011/65/EU

2014/30/EU

2014/35/EU

and following standards:

EN ISO 12100; EN 60204-1; EN 12151; EN 55014-1,2; EN 894-3; EN ISO 13857; EN ISO 3744

Acoustic power measured at 92dB (LWA) and guaranteed by 95dB (LWA).

Procedure: Article 14 Annex V 2000/14 / EC

The company named above will keep on file for review the following technical documentation:

- Operating and maintenance instructions
- Technical drawings
- Risk assessment
- Description of measures designed to ensure conformity
- Other technical documentation, e.g quality assurance for design and production

Name and address of the person (established in the Community) compiled the technical file:

Fabriqué en RPC, Im porté par: ORION 42, Zac du Capiscol, 34500 Béziers, France

Responsible for making this declaration is the:

Manufacture

Authorized representative established within the EU(if applicable)

Yangzhou Ailida Electromechanical Manufacturing Co.,Ltd.

扬州市艾力达机电制造有限公司

PRESIDENT

Gaoyou City, 05/2016

(place) (date)

(company stamp and legal signature)

Contents:

1. DESIGNATION.....	4
2. SPECIFICATION.....	4
3. TECHNICAL CHARACTERISTICS	4
4. WORK SAFETY	4
5. TRANSPORT AND STORAGE	6
6. INSTALLATION INSTRUCTIONS	6
7. PART LIST	10
8. INSTRUCTIONAL MANUAL.....	12
9. MANUAL FOR MAINTENANCE AND REPAIR	12

1. DESIGNATION

Gravity mixer material with electric drive is intended for making the concrete mixtures of liquid, semi-liquid and plastic consistency and the production of cement and cement - calcium mortars. May also be used for mixing bulk materials. Its use for other purposes will be understood as a use that does not match the destination.

2. SPECIFICATION

Specification	Unit	37515, 37516
Drum volume	l	162
Drum speed	Min ⁻¹	36±1
Power	W	650
Voltage	V/Hz	230/50
Degree of protection		IP 44
Material of chaplet	-	Cast IRON
Dimensions: Lenght	mm	1180
Width	mm	710
Hight	mm	1310
Weight	Kg	56
LpA	dB (A)	71
LwA	dB (A)	95
K	dB (A)	3

3. TECHNICAL CHARACTERISTICS

The mixer consists of the following groups:

- Mixers frame welded from profiles to which they are attached with screws leg on one side and part with wheels on the other.
- Mixing drum with blades mounted with bearings to the tilting frame of the drum.
- Tilt mechanism and the positioning mechanism of the mixer drum, which consists of a tilt wheel with the pawl, spring and latch flange.
- Drive mixer consists of electric installation, belt and tooth gear. The gear train comprises a drive wheel rim and cast iron.
- Group of electrical installations, whose basic elements are: electric motor, switch, wiring, fork insulation.

4. WORK SAFETY

For your safety, work during operation or maintenance agitator please observe the following:

- before joining the labor agitators need to be familiar with this manual
- prohibits the use of mixers by children

CAUTION! Categorically prohibits operation of mixer without insulating cover drive.

- prohibits the repair and maintenance mixer during operation. Removing the insulating cover, regular inspection, removal purchase can perform after being unplugged from the socket.
- during idle mixer is necessary to pull the plug from the socket
- before connecting to the network, you must make sure that the power cord is damaged
all activities carried out in the vicinity of the engine and the electrical installation can be performed only by qualified staff.

SAFETY SIGNS



1. Read the instruction manual
2. Ban operate mixer by children
3. If damaged cord or plug is not connected to the network device
4. Use the appropriate wiring / plug, plug, cable /
5. Before making repairs, disconnect the device from the mains

Signs and markings must be protected from damage and dirt.

Occurring hazards:

a) Associated with the use and operation:

- electric shock in case of:
 - power cord damage
 - work with the removed or damaged housing cover
- rollover mixers due positioned on uneven ground
- suffering an injury in the case of performing maintenance repairs during operation mixer

b) Associated with service and cleaning

- Suffering an injury in the event of:
 - insertion of the hand, shovels, etc.. to the spinning drum,
 - cleaning (removal of deposits) inside the drum

5. TRANSPORT AND STORAGE

The mixer can be transported by any means of transport. It should be arranged against moving for example feet nailed to the floor and fixing wheels like. The mixer is necessary to store in a manner that protect it from mechanical damage and corrosion.

6. INSTALLATION INSTRUCTIONS

1. Mounting frame mixer

Use the screws to assemble the frame mixer see fig. bellow

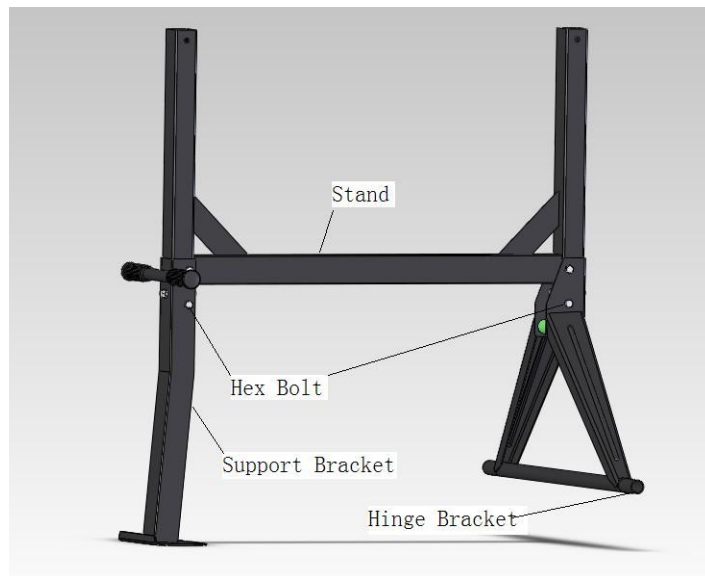

2. Mounting wheels

The wheels is to be mounted on the axle of the frame and attached by split pin see fig. below

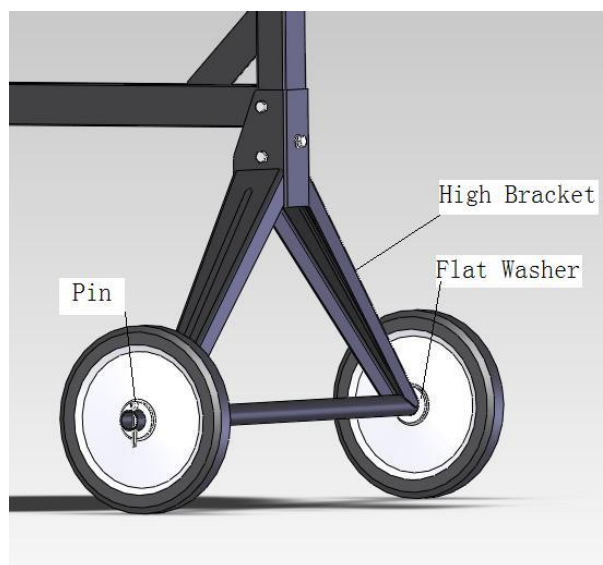

3. Mounting frame of drum

Using screws connect the frame with the frame drum mixer so that the side to connect the power unit was above ground wheels as in the picture below

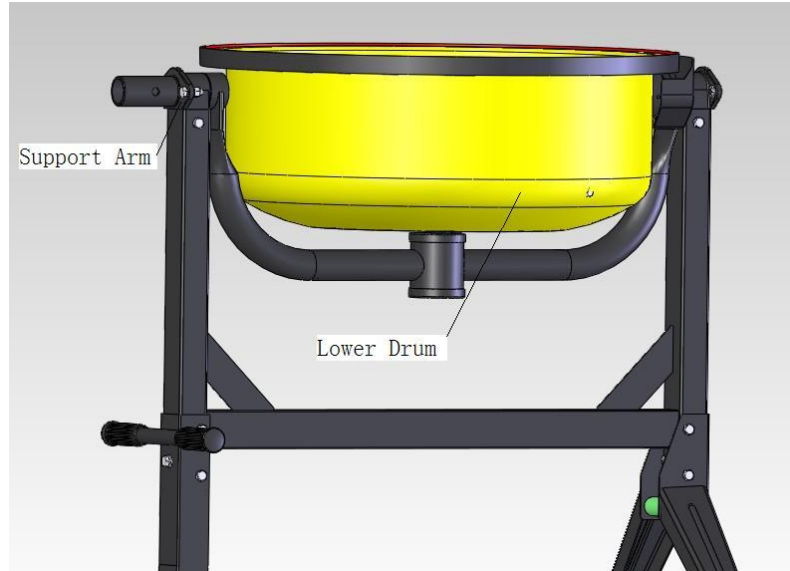

Be ware of the correct mounting of engine plate!

Make sure the shaft is directly perpendicular to the stand. The shaft can be tilted slightly down with a screwdriver as see fig. 1, 2, 3, 4

Fig. 1

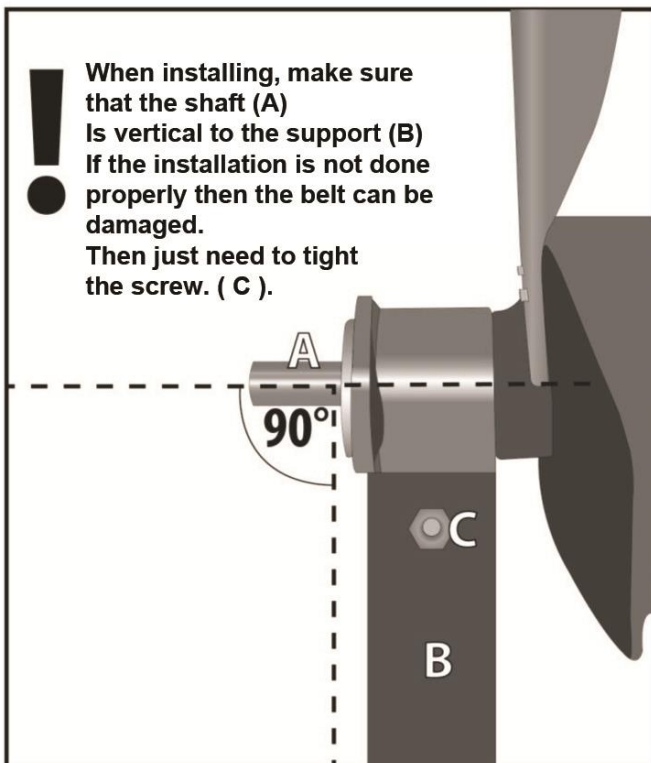

Fig. 2

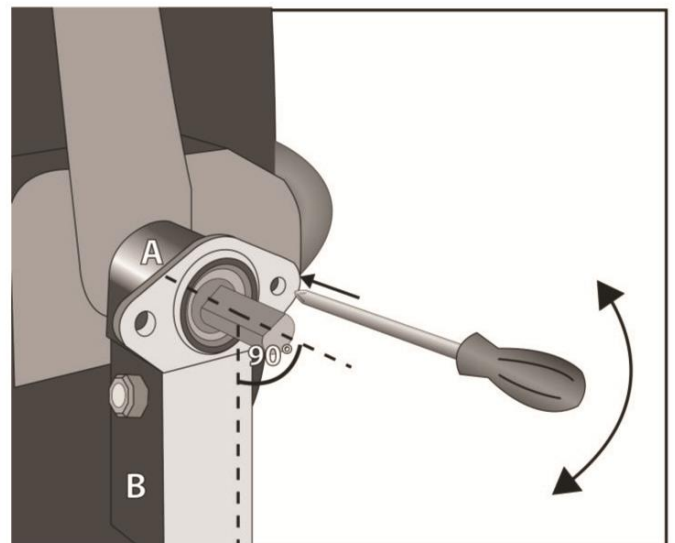

Fig . 3

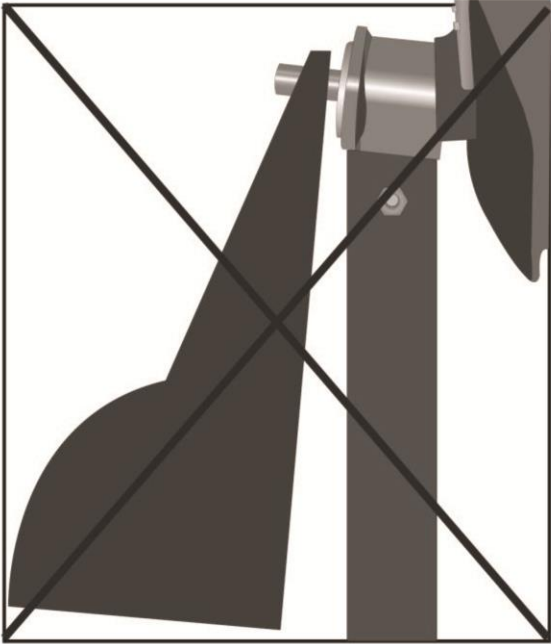
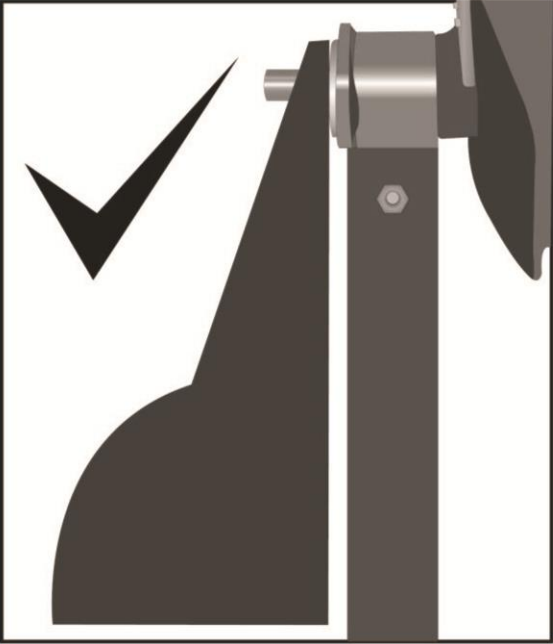
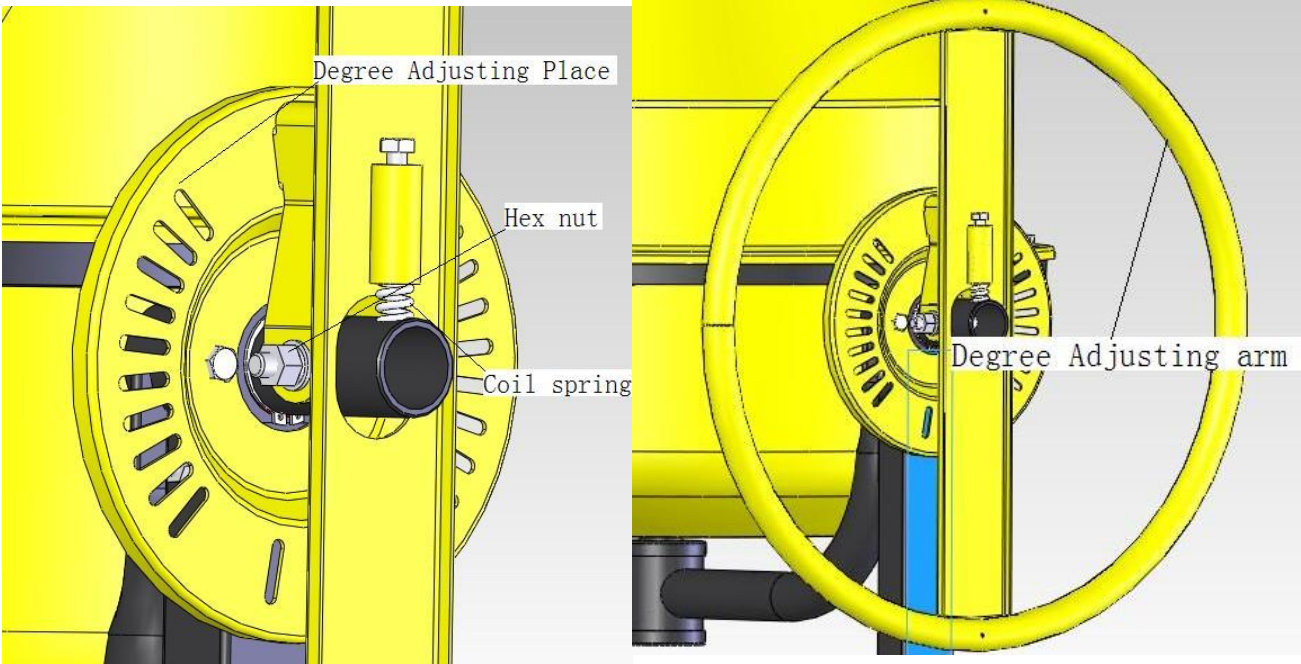

Fig. 4



4. Mounting tilt mechanism

With screws and springs assemble tilt mechanism see fig. below



5. Removal of the upper part of the drum, and mixing blades

Between the upper and lower portion of the drum insert seal. The upper part of the lower set, so that the screw holes for mounting the blades were in one plane on both drums. The upper and lower part screws together.

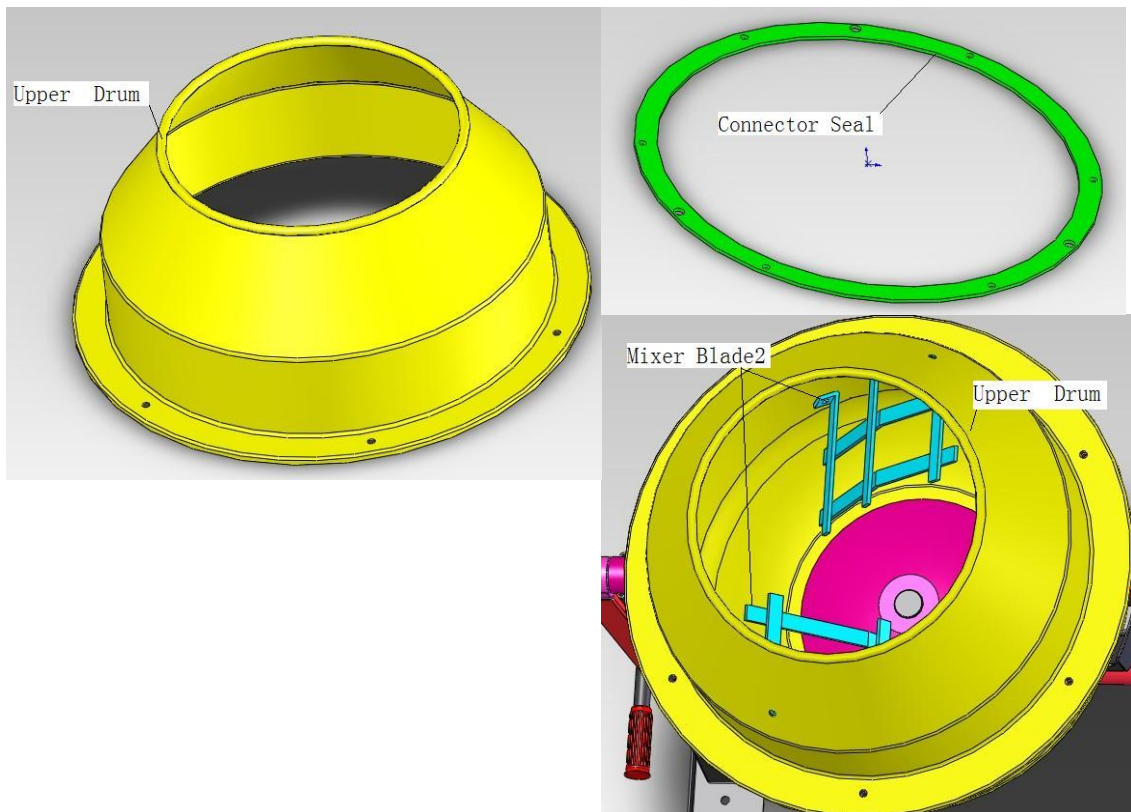

6. Mounting drive

Drive settles to the drive shaft, which must fit together by cutting the shaft and hub bore belt reel placed inside the drive. After slipping on the drive shaft of the drive must be bolted to the frame mixer fig. below. When mounted, you must manually check rotational movement of the drum drive.

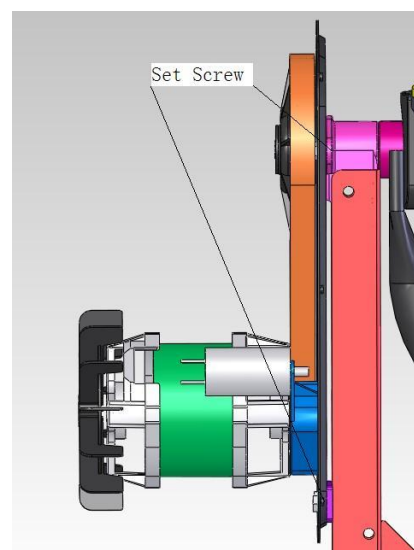
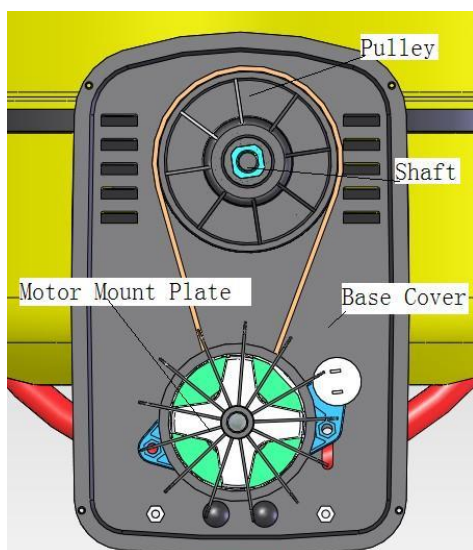

7. PART LIST

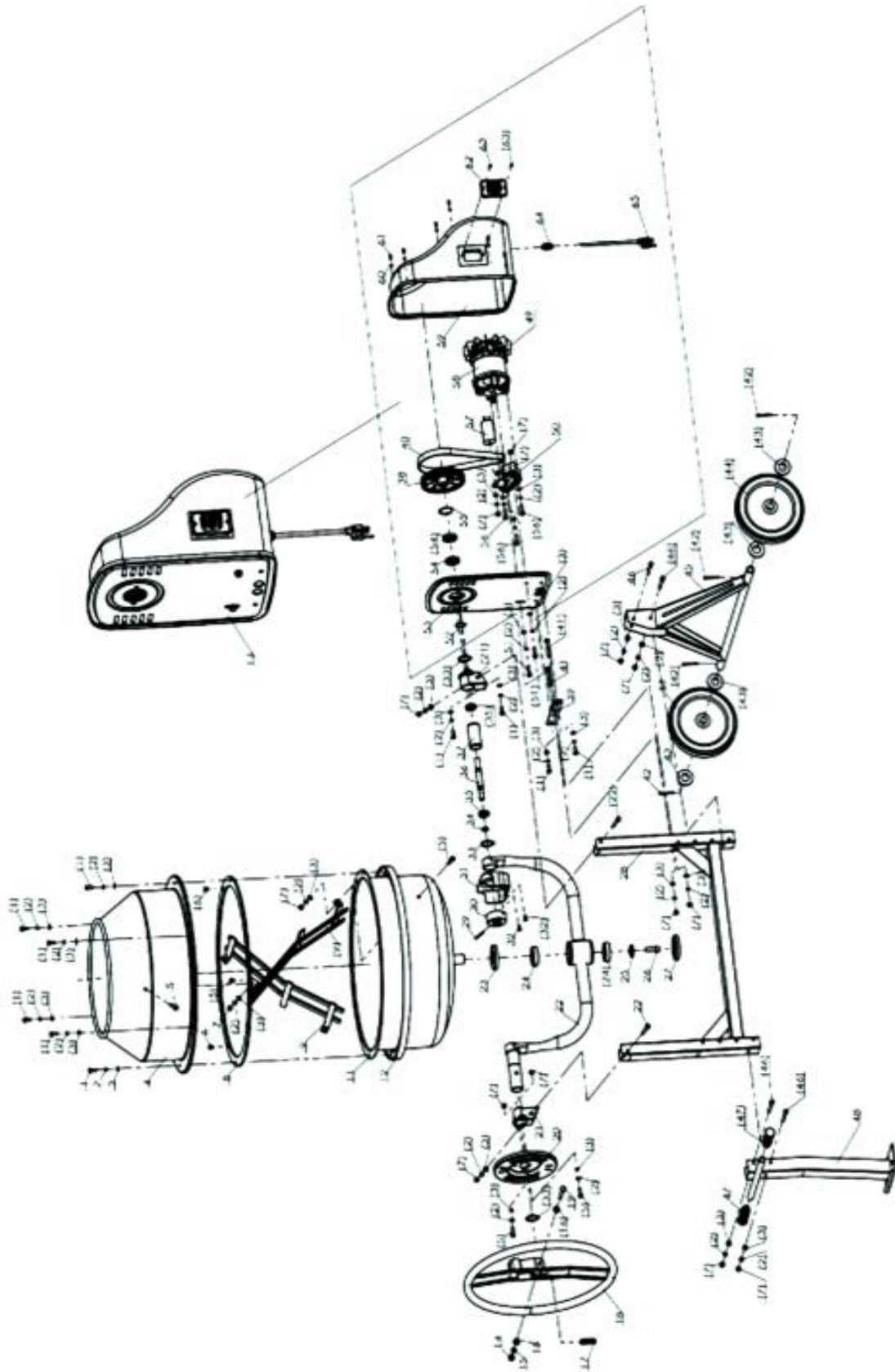

Part list

NO	English Name	Spec	Qty				
				33	Shaft ring	40	3
1	Hexagon bolt	M8X20	10	34	Washer		1
2	Spring washer	8	30	35	Bearing	6003-2Z	2
3	Flat washer	8	30	36	Shaft		1
4	Upper drum		1	37	Right tube		1
5	Hexagon bolt	M8X25	6	38	Pulley	PA6-GF30	1
6	Cross recessed pan head screw	M8X10	3	39	Fixed plate		1
7	Hexagon nut	M8	17	40	Belt		1
8	Gasket for drum		1	41	Half round head bolt	M8 X 60	2
9	Blade		2	42	Split pin	5x40	4
				43	Washer	25	4
11	Lower drum		1	44	Wheel		2
12	Gearing ring		1	45	Triangular frame		1
13	Assembly for motor		1	46	Hexagon bolt	M8X70	4
14	Hexagon nut	M10	1	47	Transport handle		2
15	Spring washer	10	1	48	Straight frame		1
16	Flat washer	10	1	49	Fan	PA6	1
17	Compression spring		1	50	Fixed base for motor	PA6-GF30	1
18	Round handle		1	51	Hexagon bolt	M8 X 30	2
19	Hexagon bolt	M10X70	1	52	Shaft ring	30	1
20	Index plate		1	53	Welding part for pulley		1
21	Supporting pedestal		2	54	Bearing	6906-2Z	2
22	U style frame		1	55	Hole ring	47	1
23	Gasket ring		1	56	Inner hexagon screw	M8X25	3
24	Bearing	6206-2Z	2	57	Capacitor		1
25	Lock washer		1	58	Motor		1
26	Inner hexagon bolt	M12X25	1	59	Plastic cover for motor		1
27	Gasket ring		1	60	Flat washer	5	6
28	H style frame		1	61	Cross head screw	M5X12	6
29	Pin	5x45	1	62	Switch		1
30	Bevel gear		1	63	Tapping screw		2
31	Guard for bevel gear		1	64	Wire grip		1
32	Cross head screw	M6X16	2	65	Cable		1

8. INSTRUCTIONAL MANUAL

Qualifications and duties of operating personnel

The mixer can be used by adults who are familiar with the contents of this manual and follow the guidelines of safety and hygiene, instructions for operation and maintenance, and general safety rules.

The duties of the service staff include:

- maintaining the mixer in a clean and proper condition
- performing periodic technical inspections
- compliance with rules and regulations and work safety and hygiene

Preparation of the mixers for action

Mixer clean from dirt and dust and place to adequately hard, flat surface.

1-phase electric motors mixers connect to 230V / 50Hz

Caution! Categorically prohibiting the use blender without actuator housing.
--

Gear of mixer drum – do not grease!

Before connecting the mixer to the network should be checked:

- activity gear manually rotating the drum,
- if the power cord is undamaged and that the power switch is turned off.

Connecting and disconnecting the power plug to plug the mixer must be done without power it means -off switch. After these measures, it is necessary to turn mixer (drum upright) and observe the work of mixers idle, while paying attention to whether the drum rotates uniformly without squeaking and jams, and that the direction of rotation of the drum in the opposite direction clockwise.

These mixers have the character of a so-called phase. That work is the following sequence: loading the individual components, mixing, emptying.

Drum filled in accordance with recipe is accomplished manually / shovel, bucket).

The first step is the pouring of water, then pour cement and gravel, and adding the remaining water. Emptying the finished mixture is carried out with activated mixer while running deflection drum.

9. MANUAL FOR MAINTENANCE AND REPAIR

Since proper and careful maintenance depends correct operation and durability mixers. Maintenance includes the following activities: cleaning the mixer after each use (particularly drum), control of screw joints, regular lubrication of rotating parts in accordance with the lubrication schedule, check all important parts and remove defects.

Periodic inspection, troubleshooting, removing the cover should be carried out after pulling the plug from the socket.

Damage and repair

1. **Engine does not rotate** – check if it's plugged in electricity.
2. **Engine does rotate but the drum doesn't** – multiple groove belt is damaged, it must be replaced.
3. **Driving wheel Z-12 skips along the rim** - too worn wheel drive, it should be replaced. Maladjusted clearance between the teeth – tune
4. **Damaged engine** – seek help of electrician

WARRANTY CERTIFICATE

CONCRETE MIXER

CM180L []

Date of manufacture.....

The above mentioned mixer has been manufactured in accordance with current design and technological documentation and in accordance with current corporate standards.

WARRANTY TERMS:

1. The guarantee is provided for the correct operation of the mixer for a period of 24 months from the date of purchase.
2. The warranty period shall not exceed a period of 24 months from the date of shipment mixers to distributor.
3. Warranty obliges manufacturer to eliminate production defects discovered by users / defective design, improper use of material / - by the deadline of 30 days from the date of fault detection and reporting complaints to users (sellers), together with this Warranty Certificate.
4. In case of electric engine failure, the user is obligated to send by mail the entire drive together with valid warranty certificate, to the address of mixer manufacturer.
5. The guarantee becomes invalid if: improper storage, use that does not match the operating instructions, repairs and changes without the consent of the manufacturer.
6. During 10 days from the date of purchase is necessary to check whether the mixer is complete and that there is no mechanical damage. Subsequent complaints regarding the completeness and damage during transport will not be considered.
7. Blank and unsigned warranty certificate is invalid
8. In case, the claim is not valid, all costs associated with repairing are covered by the user.

QUALITY CONTROL DEPARTMENT

Serial number ¹.....

(fills selling point)

Stamp of selling point

.....
(Date of purchase + sign of seller)

LEVIOR s.r.o.
Tovačovská 3488/28, 750 02 PŘEROV
Tel.: 00420 - 581 - 746256-58
Fax: 00420 - 581 - 746255
LEVIOR@LEVIOR.CZ
www.levior.cz

¹ Specify the number of manufacturing a label located on the cover of the drive.